

Similar to our Ressisto range, Paveezzi Composites Riviera decking boards are made up of 95% recycled material (65% of which is reclaimed wood fibres and 35% recycled plastic), and uses advanced co-extrusion technology which generates an externally durable outer layer. As the name suggests, the Riviera board is 50% wider than a standard decking board, for an elegant and contemporary look - which has the added benefit of being quicker to fit. Paveezzi Composites Riviera decking has a dual surface finish with a wood grain on each side: the front of the board is coloured in 3 combo boards: Maple / Charcoal, Teak / White Beach, Siberian Ash / Ebony - a perfect alternative or accompaniment to stone or ceramic paving.

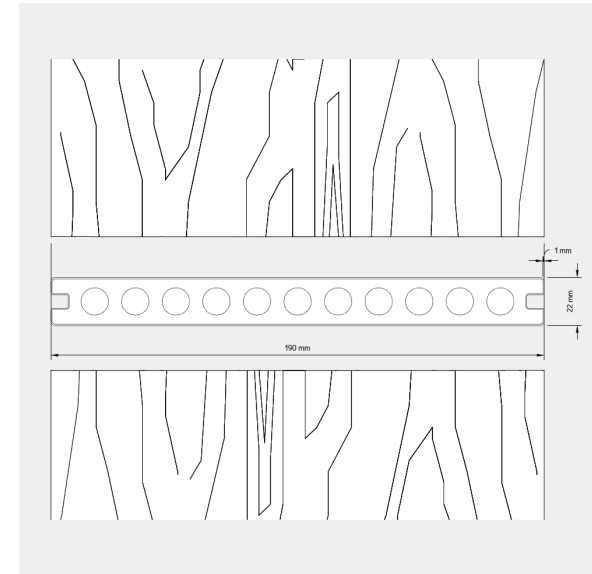

Riviera Decking

Length (mm)	3600
Width (mm)	190
Height (mm)	23
Weight (p/lm)	4.3kg
Material	Wood Plastic Composite
Finishes	Woodgrain



Length

3.6m PAV190

RIVIERA DECKING BENEFITS

Paveezzi Composites Riviera decking has all the benefits of our co-extruded Ressisto range, due to the HDPE capping. This results in a decking board that is more hardwearing, stain-resistant, and resistant to colour fading. We are so confident in the quality of our board that we offer an industry-leading 25 year warranty.

Why Choose Paveezzi Composites?

Paveezzi are committed to ethically sourcing and providing the highest quality composite products such as our range of composite decking, composite cladding, composite fencing and more.

We believe sustainability and recycled materials are essential for the future of our environment. Our products are an innovative blend of reclaimed FSC® wood fibres (otherwise used as landfill) and recycled HDPE, producing a product which is 95% recycled.

4495 Tons of plastic
TONS OF PLASTIC IN 2021

Sustainable Choice

Paveezzi Composites Wood Plastic Composite products are made from recycled plastic and wood fibre. Choosing Paveezzi Composites ensures this waste material is diverted from landfill, and given a second life.

25 YEAR WARRANTY

LOW MAINTENANCE

SLIP RESISTANT

FAST, EASY INSTALL

UV STABLE

HIDDEN FIXINGS

Great Composite Benefits

Not only easy to install, with our hidden clip system, Paveezzi Composites decking is practical: with low maintenance, and slip resistant properties & with our long warranties, will be sure to look good for years to come.

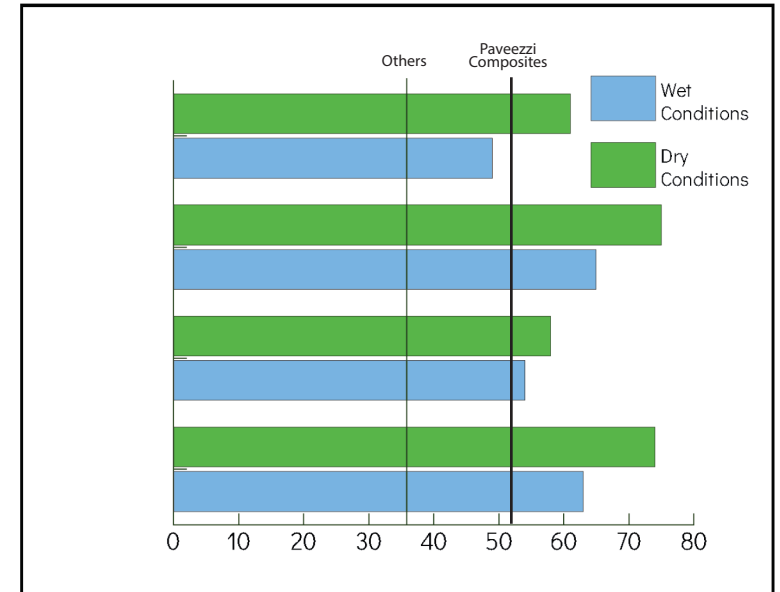

Slip Resistance

Paveezzi Riviera is our best performing decking board with respect to slip. The slip test results above show that Grande decking boards far exceed the required PTV value of 52 required to be classified as low slip potential on both sides, when tested in wet and dry conditions, across the width of the board (W) and along the length of a board (L). This makes Paveezzi Riviera an excellent choice where safety is a primary concern.

**WORKING SPECIFICATION
- DECKING SYSTEMS**

Drawings below show a typical substructure detail for Paveezzi Composites decking (shown here with Paveezzi Composites Plastic Joist Substructure).

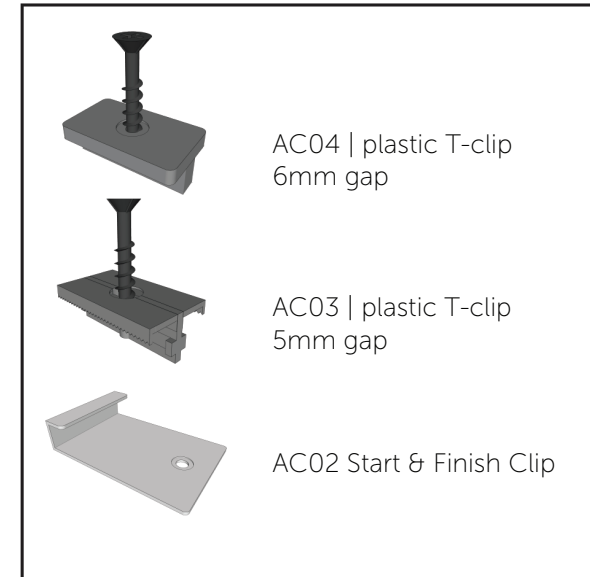
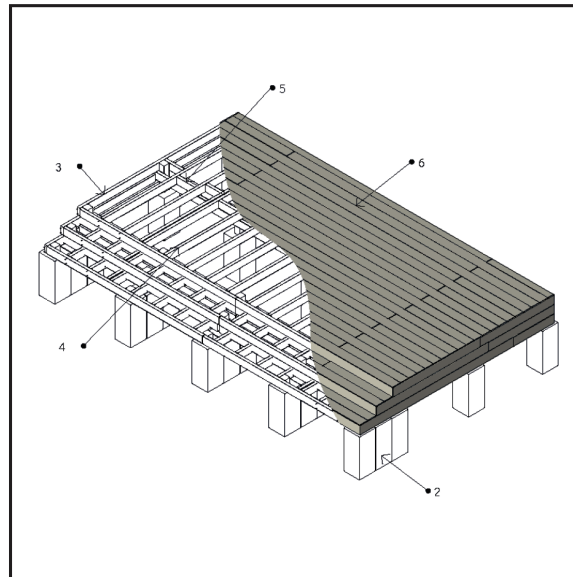
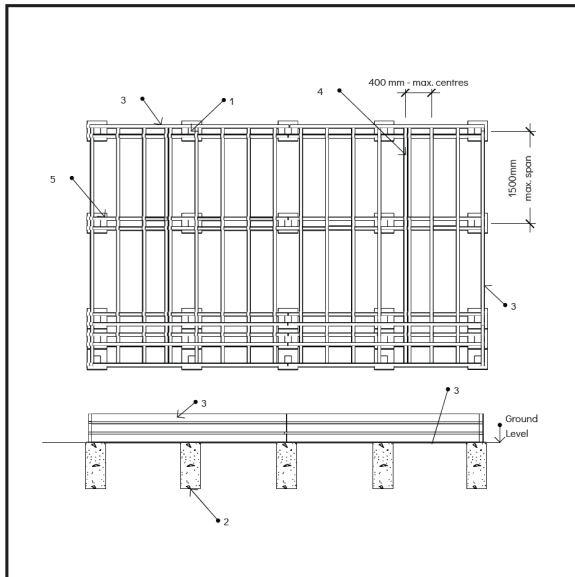

Paveezzi Composite decking boards must be supported by joists placed at 400mm centres.

For further information, please see "Paveezzi Installation"
www.paveezzicomposites.com.au

Paveezzi Composites Riviera decking board should always be used with Paveezzi Composites clip system to allow for thermal expansion, with our unique Locking Clip used to keep boards held in place for years to come.

SPECIFICATIONS TABLE

Property	Test Method	Test Result	Test Requirements	Verdict
Appearance	EN 15534-1:2014 Section 6.1 EN 15534-4:2014 Section 4.3	There is no obvious defects and difference between specimens in appearance		Pass
Sliperiness (Pendulum Test)	EN 15534-1:2014 Section 6.4.2 CEN/TS 15676:2007 EN 15534-4:2014 Section 4.4	Chateau Side: Length: 61 (Dry) / 54 (Wet) Width: 75 (Dry) / 63 (Wet) Dovetail Side: Length: 58 (Dry) / 54 (Wet) Width: 74 (Dry) / 63 (Wet)	Pendulum value≥52	Pass
Linear Mass	EN 15534-1:2014 Section 6.5 EN 15534-4:2014 Section 4.4	Mean: 4.32 kg/m Min.: 4.27 kg/m	Individual values≥95% declared value by the manufacturer.	Pass
Dimensions	EN 15534-1:2014 Section 6.6 EN 15534-4:2014 Section 4.4	Mean Thickness: 21.64 mm Mean Width: 224.99 mm Mean Length: 1048.7mm Deviation from straightness: 0.8 mm/1000mm Max. Cupping: 0.35 mm		
Falling mass impact resistance	EN 15534-1:2014 Annex A EN 15534-4:2014 Section 4.5.1	Type Hollow profile Max. Crack length (mm): No crack	None of 10 test specimens shall show a failure with a crack length ≥ 10 mm or a depth of residual indentation ≥ 0,5 mm.	Pass
Flexural properties	EN 15534-1:2014 Annex A EN 15534-4:2014 Section 4.5.2	Maximum Load: Mean: 3487 N Min.: 3375 N Deflection at 500 N: Mean: 1.19 mm Max. 1.23 mm	Flexural properties -Fmax: Mean ≥ 3300 N Min. ≥ 3000 N -Deflection under a load of 500 N Mean ≤ 2,0 mm Max.≤ 2,5 mm Span: 432 mm	Pass
Creep behaviour	EN 15534-1:2014 Section 7.4.1 EN 15534-4:2014 Section 4.5.3	Span: 400 mm Mean ΔS: 2.97 mm Max. ΔS: 3.03 mm Mean ΔSr: 1.81 mm	Known span in use Mean ΔS ≤ 10 mm Max. ΔS ≤ 13 mm Mean ΔSr ≤ 5 mm	Pass
Resistance to artificial weathering	EN 15534-1:2014 Section 8.1 EN 15534-4:2014 Section 4.5.5 ISO 4892-2: 2013, cycle 1	After 2000h exposure: ΔL* = 5.59, Δa* = -0.82, Δb* = -0.67 ΔE* = 5.70 Grey scale = 2-3	ΔL*, Δa* and Δb* shall be declared	N/A
Swelling and water absorption (28 days immersion)	EN 15534-1:2014 Section 8.3.1 EN 15534-4:2014 Section 4.5.5	Mean Swelling: 0.78% in thickness ; 0.35% in width; 0.27% length Max. Swelling: 0.97% in thickness; 0.45% in width; 0.29% in length Water Absorption Mean: 3.25% Max.: 3.38%	Mean Swelling: ≤4% in thickness ; ≤0.8% in width; ≤0.4% length Max. Swelling: ≤5% in thickness; ≤1.2% in width; ≤0.4% in length Water Absorption Mean: ≤7% Max.: ≤9%	Pass

Property	Test Method	Test Result	Test Requirements	Verdict
Moisture resistance under cyclic test conditions	EN 15534-1:2014 Section 8.3.2 EN 15534-4:2014 Section 4.5.5	Original MOR: 21.0 MPa After exposure, Mean MOR: 19.8MPa Decrease: 5.7 % Min MOR: 19.3 MPa Decrease: 8.1 %	Decrease of bending strength. Mean ≤ 20 % Max. ≤ 30 %	Pass
Boiling Test	EN 15534-1:2014 Section 8.3.3 EN 15534-4:2014 Section 4.5.5	Water absorption in weight: Mean: 1.03 % Max.: 1.06 %	Water Absorption in weight: Mean ≤ 7 % Max. ≤ 9 %	Pass
Linear thermal expansion coefficient	EN 15534-1:2014 Section 9.2 EN 15534-4:2014 Section 4.5.6 ISO 11359-2:1999	Mean: Longitudinal direction: 48 ×10-6 K-1	≤ 50×10-6 K-1	N/A
Heat Reversion	EN 15534-1:2014 Section 9.3 EN 15534-4:2014 Section 4.5.7 EN 479:2018	Test Temperature: 100°C Mean: 0.06 %		
Heat build-up	EN 15534-1:2014 Section 9.4 EN 15534-4:2014 Section 4.5.7	Set temperature rise for use in horizontal position: 50 °C Actual temperature rise for black control specimen: 50.0 °C Temperature of test specimen: 46.5 °C Predicted heat build-up ΔT: -3.5°C	At least 2 °C	Pass
Resistance to indentation	EN 15534-1:2014 Section 7.5 EN 15534-4:2014 Section 4.5.7	Brinell hardness: Chateau: 54.0 MPa Dovetail: 52.6 MPa	Indenter: a hardened steel spherical body with diameter of 10 mm Test load: Additional load of 2000N with preload of 20N Indentation time: (25 ± 5) s Recovery time: at least 24h >50 MPa	Pass
Neutral salt spray test	EN 15534-1:2014 Section 8.6 ISO 9227:2017 EN 15534-4:2014 Section 4.5.7	After 24h exposure: Chateau ΔE = 0.36, Dovetail ΔE = 0.12		
Moisture content	EN 15534-1:2014 Section 6.3	0.28%	<1%	Pass
Fire Resistance	EN 13501-1:2018	Standard Option Classification: C _s -S 1	FR-Rated Option Classification: B _s -S 1	

For more information, please contact Paveezzi Composites team