

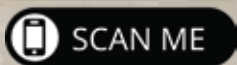

**PAVEZZI**  
COMPOSITES

# CLADDING INSTALLATION AND CARE GUIDE



# TABLE OF CONTENTS

## PRE-INSTALLATION

Pre-Installation	03
ToolsForTheJob	04
Handling Your Cladding	05
Colour Characteristics	06
Cladding Components	07

## INSTALLATION GUIDELINES

Installation Of Subframe	
Important Considerations	09
Subframe Design & Layout	10
Fixing Cladding Joists	11

## INSTALLATION OF CLADDING BOARDS

Laying Patterns	13
Horizontal Installation	14
Vertical Installation	18

## INSTALLATION OF EDGING OPTIONS

Installing Our Edging Around Windows & Doors	20
Installing Our Edging Around Windows & Doors	21

## CARE GUIDE

Routine Cleaning	23
Stubborn Spot Stains	23
Water Staining	24
Surface Mildew & Mould Growth	24



This installation guide is purely a guidance document on how to install Paveezzi products. We understand that not every project will use all of the products outlined, but we recommend that key elements should be followed regardless of the chosen sub-structure solution.



## PRE-INSTALLATION

Key areas should be considered prior to embarking on the installation of your Paveezzi cladding and ancillary products. This section shall cover advice on handling, recommended tools for the job and a selection of principal elements to consider ahead of installation.



- Ensure a suitable, flat area is cleared to store your cladding prior to installation. Laying your cladding boards and any accompanying accessories, such as trims, on wooden/aluminium battens at approximately 400-500mm spacings will ensure that the material avoids any sitting water, dirt or grit that may scratch or damage the products ahead of installation.
- When storing your boards outside for an extended period of time, be sure to cover them with a layer of sheeting.
- Take extra care when lifting, moving or fitting boards to avoid accidental scratching. Do not drag, slide or drop boards when laying over one another.
- Keeping your work area as tidy as possible will help to keep the surface of the boards free of any construction debris.



## PAVEZZI ADVICE

### How Temperature Can Affect Your Cladding

Composite materials are receptive to temperature. Allow a period of at least 24 hours prior to installation for your cladding boards to climatise to the outside environment.

# PRE-INSTALLATION - TOOLS FOR THE JOB

## RECOMMENDED TOOLS



HAMMER DRILL



HAND DRILL



TAPEMEASURE



PENCIL OR CHALK



JIG SAW



CIRCULAR / MITRE SAW



SPIRIT LEVEL



CARPENTRY SQUARE

## SAFETY & PPE



EAR PROTECTION



SAFETY GLASSES



SAFETY GLOVES



LONG SLEEVES



DUST MASK



SAFETY FOOTWEAR

## TOOL TIPS

- Standard wood working tools can be used with Pavezzi composite cladding.
- We recommend carbide-tipped blades for the cleanest saw cuts. When using circular saws we recommend a 40-50 teeth blade.
- Use a 3mm drill bit for countersinking.
- If you are unsure on how to use a specific tool, please consult the tool manufacturer's user manual.

# PRE-INSTALLATION – ELEMENTS TO CONSIDER

## PRE-PLANNING

The size, shape and orientation of your cladding area should be considered in the early phases of your project. You will need to establish your chosen laying pattern as this will dictate the placement of your joists and the placement of joins (and additional joists) if necessary.

Also factor in any fixed elements such as window sills, door openings and guttering when planning the design, shape, location, and orientation of your cladding project.

## SUBFRAME OPTIONS

Our cladding system should not be installed without a framework in place. All cladding boards must be installed directly onto a subframe of composite, plastic, timber, or metal joists. We urge users to check the fire rating of all building materials used to ensure that they are in accordance with most up-to-date your local building regulations.

## VENTILATION REQUIREMENTS

Ventilation is a key factor in removing moisture from the material, which in turn ensures the long-life of Paveezzi cladding products. Allow a minimum of 25mm space behind the cladding boards to ensure adequate airflow. There should also be a continuous 15mm gap left at the top and the bottom of the system to ensure adequate ventilation.

## TEMPERATURE

Composite cladding naturally expands and contracts in varying temperatures. It is advised that suitable gaps should be maintained at end-to-end joins as outlined in adjacent illustration and table.

TEMPERATURE GUIDANCE TABLE	
Outside Temperature	End-To-End Gap
Below 4°C	6mm
Between 4°C - 25°C	3mm
26°C or over	1mm



# PRE-INSTALLATION - COLOUR CHARACTERISTICS

## CAPPED COMPOSITE CLADDING

Our capped composite cladding boards (Paveezzi composites RESSISTO FineLine & RESSISTO Castellated ranges) come equipped with a protective polymer shell, ensuring high UV and fade resistance. They have been designed to have a high quality dual-toned appearance. The colour tone of these boards shall slightly vary from board-to-board to mimic a more authentic, real woodgrain finish. Consideration of this should be taken upon installation.



### PAVEEZZI ADVICE

#### Account For Wastage

While our cladding calculator should provide you with a good indication on requirements, we recommend that you allow for a 5-10% wastage allowance.



**Primary Colors Range**  
**FineLine Woodgrain Capped Cladding**  
Dimensions: 160mm x 18mm x 2900mm















**Additional Colors Range**  
**Castellated Brushed Capped Cladding**  
Dimensions: 160mm x 18mm x 2900mm

# PRE-INSTALLATION - CLADDING COMPONENTS

 <p><b>Aluminium Joists</b> Dimensions: 40mm x 25mm x 3600mm</p>	 <p><b>Skirting Trim</b> Dimensions: 120mm x 11mm x 3600mm</p>	 <p><b>Corner Trim</b> Dimensions: 45mm x 45mm x 3600mm</p>	 <p><b>FineLine Cladding Main Clips</b> 100 clips &amp; screws per box</p>
 <p><b>Starter Clip Set</b> 100 clips &amp; screws per box</p>	 <p><b>Cladding Screws</b> Dimensions: 5mm x 50mm (100 per box)</p>	 <p><b>Coloured Trim Screws</b> Dimensions: 4mm x 35mm (100 per box)</p>	 <p><b>FineLine Cladding Finisher Alu Profile</b> Lenght: 3600mm</p>
 <p><b>FineLine External Corner Alu Profile</b> Lenght: 2900mm</p>	 <p><b>FineLine Internal Corner Alu Profile</b> Lenght: 2900mm</p>	 <p><b>FineLine T-Joiner Alu Profile</b> Lenght: 2900mm</p>	 <p><b>FineLine Start &amp; Finish Alu Profile</b> Lenght: 2900mm</p>

# PRE-INSTALLATION - CLADDING COMPONENTS

 <p><b>Ressisto Castellated Cladding</b> Dimensions: 170mm x 26 mm x 3600mm</p>	 <p><b>Window &amp; Door Internal Alu Profile</b> Lenght: 3600mm</p>	 <p><b>Window &amp; Door External Alu Profile</b> Lenght: 3600mm</p>	 <p><b>Aluminium Joists</b> Dimensions: 40mm x 25mm x 3600mm</p>
 <p><b>Internal Last Board Spacer Clip</b></p>	 <p><b>Castellated Cladding Main Clip</b> 100 clips &amp; screws per box</p>	 <p><b>Starter Clip Set</b> 25 clips &amp; screws per box</p>	 <p><b>Corner Trim</b> Dimensions: 45mm x 45mm x 3600mm</p>
 <p><b>External Corner Trims</b> Lenght: 3600mm</p>	 <p><b>Start &amp; Finish Trims</b> Lenght: 3600mm</p>	 <p><b>Castellated Cladding Main Clip</b> Dimensions: 4mm x 50mm (50 per box)</p>	 <p><b>Cladding Screws</b> Dimensions: 5mm x 50mm (100 per box)</p>

## INSTALLATION OF **SUBFRAME**

All composite cladding systems require a subframe network to promote both drainage and airflow and to ensure a solid structure for the cladding boards to be fixed directly onto. We specialise in a purpose-built composite joist option; however, alternative materials can be used to create your subframe.



# INSTALLATION – IMPORTANT CONSIDERATIONS



## JOIST SPECIFICATION

There is no set requirement on the type of batten, or joist, that can be used to form your cladding framework. In fact, there are numerous different options that can be used. Regardless of the joist material, this should be a minimum of 25mm in thickness to allow for ventilation.

## PAVEEZZI'S COMPOSITE JOIST

We provide a long-life, lightweight subframe solution for our cladding boards: Our Aluminium Joist (50mm x 25mm x 3000mm). It is recommended (but not a necessary requirement) that you use this solution.

## ALTERNATIVE BATTEN OPTIONS

Alternative battens come in the form of timber or steel. If compliant with local building regulations, then both materials can be used to install Paveezzi cladding.

For the sake of our subframe installation guide, we will be using our Composite Joist to depict a typical installation. The principals outlined in the guide, however, will apply to any cladding framework, regardless of the joist / batten solution used.

## JOIST SPECIFICATION

Joist spacings should sit at no wider than 500mm, regardless of the type of batten you will be installing Paveezzi cladding onto. In high wind load areas, we suggest narrowing joist centres to 400mm. 20mm spacings between adjoining joists must be observed to account for expansion and contraction of the subframe material.

## VENTILATION REQUIREMENTS

Allow a minimum of 25mm space beneath the cladding subframe to ensure adequate airflow for the cladding system – hence why we recommend that a joist with a minimum thickness of 25mm should be used. There should also be a continuous 15mm gap left at the top and the bottom of the system to ensure adequate ventilation. Ventilation is a key factor in removing moisture from the material, which in turn ensures the long-life of Paveezzi cladding products.

### PAVEEZZI ADVICE

#### **Install A Breathable Membrane**

To aid ventilation and avoid damage that can result from moisture build up, we advise installing a breathable membrane before installing battens.

# INSTALLATION - SUBFRAME DESIGN & LAYOUT

Plotting the layout of your battens will ensure you provide adequate support to your composite cladding boards. Consider the overall design of your cladding section prior to installation. Special consideration should be taken into account for the following:

- 1 Consider Your Joist Layout In Relation To The Laying Pattern Of Your Cladding Boards.** Your joists should, in most cases, run adjacent to the direction of your cladding boards. Paveezzi cladding boards can be installed in a vertical or horizontal direction.
- 2 Consideration Of Where You Expect Cladding Boards To Meet At Butt Ends.** Double joisting is required in areas where two cladding boards are expected to meet at butt-ends.  
We suggest you can use all Paveezzi 2-part trims to achieve perfect finish all ends.  
**Note:** Please refer to page 7 for all accessories !
- 3 A Consideration Of Features Of Your Wall.** Ensure adequate batten support is installed around window sills, door openings, guttering and soffits. Refer to the illustration for an example of a typical joist layout.

## PAVEEZZI ADVICE

### Ensure Your Joist Layout Allows For Ventilation

Design your subframe to ensure 15mm gaps are observed at both the top and bottom of the cladding system.

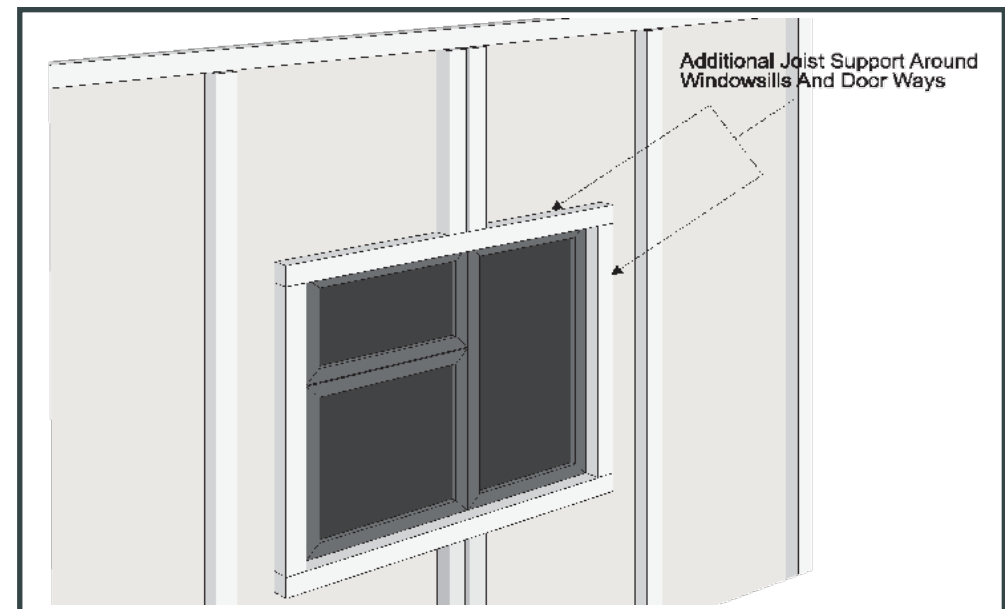
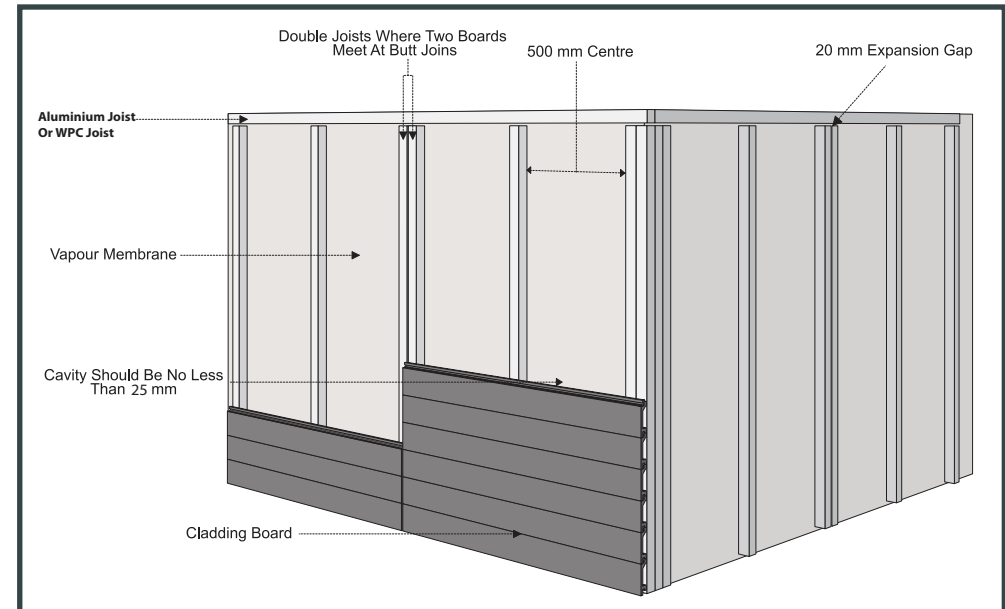

# INSTALLATION - LAYING PATTERNS

- 1 Begin Installing Joists.** Beginning from a corner or edge of the face of the wall, work inwards and space your joists evenly at 500mm centres. If a vapour barrier is being installed, ensure this is positioned and fixed securely to the existing wall prior to your joists being fixed.

To allow for adequate ventilation of the cladding system, a gap of at least 15mm should be observed between bottom of your joist(s) and the ground. This allows the adequate movement of airflow beneath the cladding system.

- 2 Allow For Adequate Expansion Gaps.** Ensure spacings of 20mm are observed where joist ends of the Composite Joists meet – the same applies if you are using timber batons. This is to allow for adequate expansion and contraction of the material.

- 3 Fix Joists Securely To The Wall.** When fixing the Composite Joist securely to the wall, each joist should be fixed at 500mm intervals along its length. We recommend using countersunk A4 stainless steel screws to securely fix your battens to the wall. Pre-drill the material prior to fixing it down to avoid the material cracking when fixed.

Ensure joists are laid level against the wall. Packers can be used to level-off any inconsistency in the level of the wall.

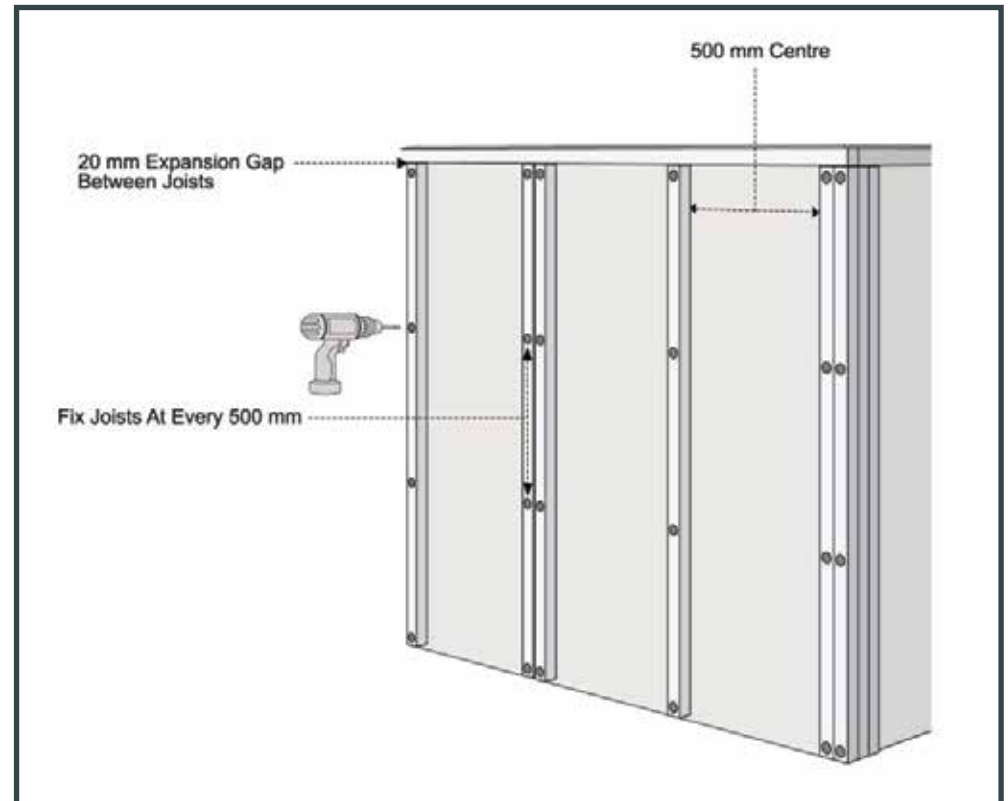



## INSTALLATION OF **CLADDING BOARDS**

Pavezzi's easy-to-use, no-thrills fixing method involves fixing the cladding boards directly to your network of joists using our purpose-built starter clips and cladding screws. Each of Pavezzi's ranges can be installed both horizontally and vertically – this guide shall provide step-by-step details on each method.



# INSTALLATION - LAYING PATTERNS

Pavezzi's composite cladding can be installed both vertically and horizontally. While the orientation of both the joists and the cladding boards change depending on the direction you wish to install them, the installation methods behind each are the same.

Consideration of your laying pattern should be taken in the planning phases of installation to ensure proper orientation of your joists and to ensure the appropriate measures are taken to fix the cladding boards securely around door openings and windowsills.

The step-by-step installation guide will focus on the horizontal installation of our cladding boards and the same principles and instructions for installation can be used for vertical installation methods



# INSTALLATION - HORIZONTAL CLADDING

## 1 ALIGN & SECURELY FIX YOUR STARTER CLIPS TO YOUR FIRST RUN OF JOISTS

Begin by attaching Starter Clips to the base of each of your joists using the stainless-steel screws provided. It is important that you mark a level line to ensure a straight row of Starter Clips are evenly fixed to your row of joists. Position and securely fix a Starter Clip at the base of each joist to ensure your first cladding board is secure.

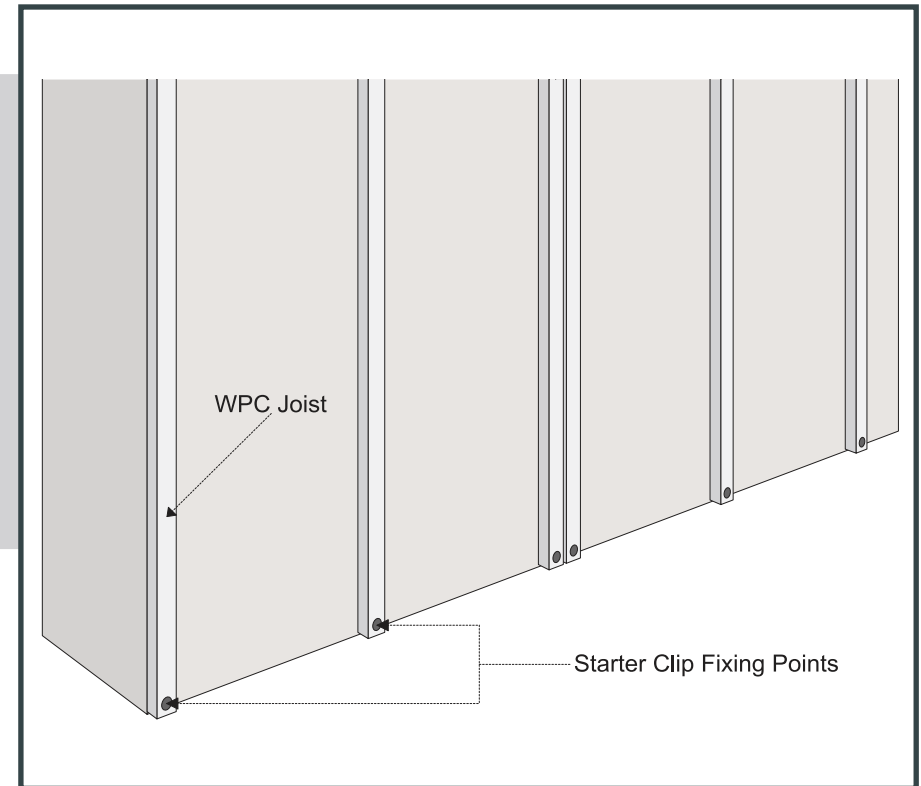
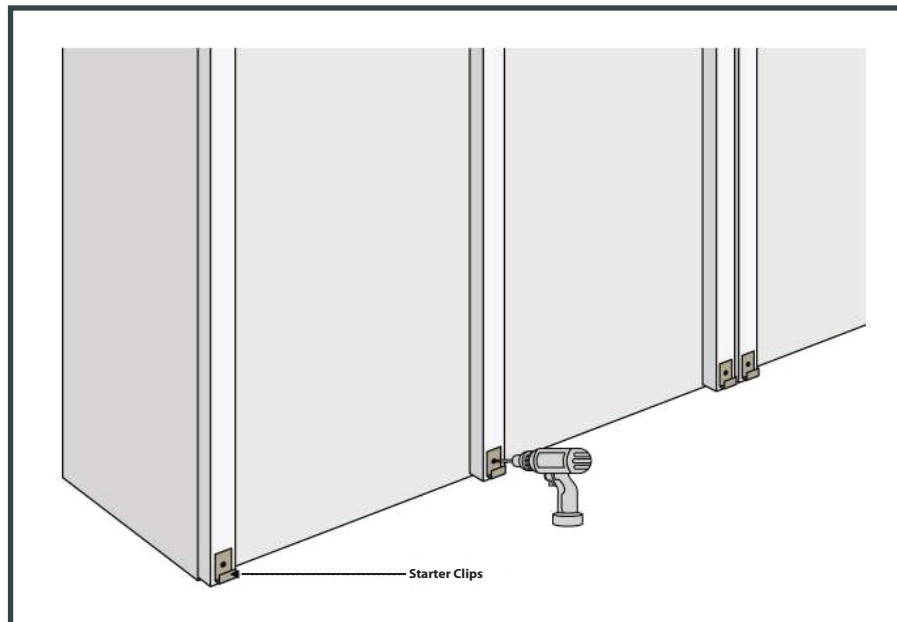

# INSTALLATION - HORIZONTAL CLADDING

## 2 FIX YOUR FIRST CLADDING BOARD

When all Starter Clips are fixed to the base of the joists, align the concealed groove of your first cladding board with the opening of your Starter Clips and position the cladding board into place. If required, tap the top of the cladding board to ensure it is securely fixed into the full run of clips.

You are now ready to fix the top of the cladding board. Firstly, position main clip onto cladding board along every joist. Be sure to hold this in place as this will not yet be fully secured. Fix the top of the cladding board to the joist with a Pavezzi Cladding Screw. Work along the length of the cladding board to ensure the board is fixed to every supporting joist.

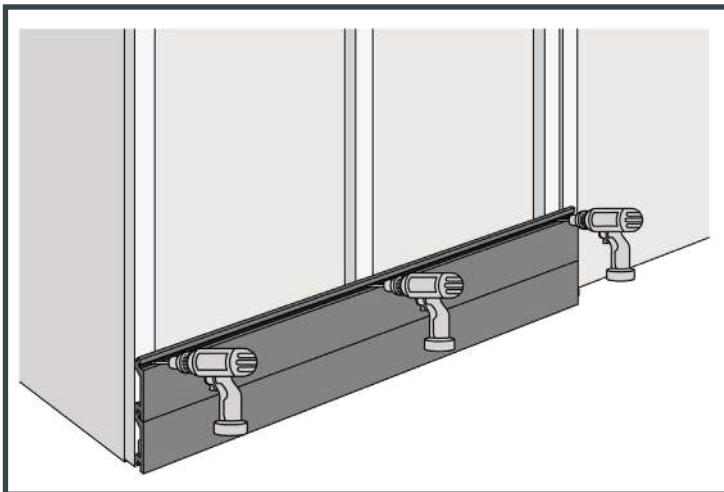
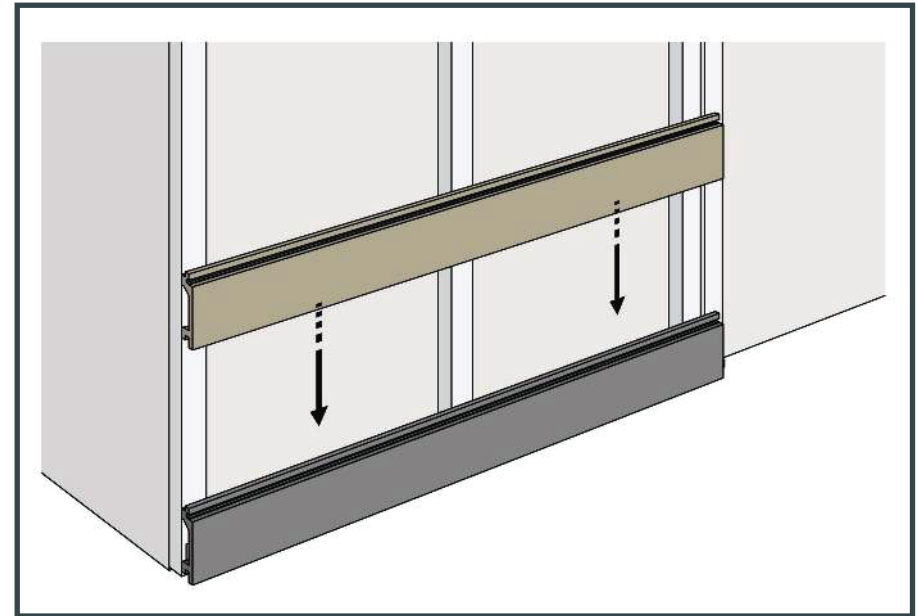

## 3 INSTALL ALL SUBSEQUENT BOARDS USING STAINLESS STEEL CLADDING CLIPS & SCREWS

Slot the concealed groove of the top of the clip groove into the top groove of your first cladding board. Once the base of the second cladding board is secure, fix the top grooved-channel by pre-drilling every board in the middle and fixing with a cladding screw, as shown in Step 2.

Repeat this process for all subsequent cladding boards. Allow for adequate expansion gaps at butt-ends of cladding boards. This gap is dependent on the temperature and specific spacings can be found on the temperature chart on page 05.

## 4 INSTALLING CLADDING BOARDS AROUND FIXTURES SUCH AS DOORS ON WINDOWS

Depending on the design of the installation and the position of fixtures such as doors and window sills, there may be a requirement to cut cladding boards along their length to suit the shape and design of the fixture

Firstly, cut the cladding board to the correct size and shape. Fix this cladding board in the conventional way where possible (slotting the concealed groove into the cladding board below and fixing the top groove onto your joist with a Cladding Screw). In areas where this is not possible, use a colour-matched Trim Screw to face fix the unsupported section of the board to a supporting joist. If you are installing our FineLine cladding board and are unable to fix this cladding board through the fixing grooves, a 12mm packer will be required to sit behind the cladding board in order to ensure a secure and proper fixing.

NOTE: USING PAVEEZZI 2-part TRIMS you should be able to finish all possible issues.

Each cladding board should be fixed at both the top and bottom.

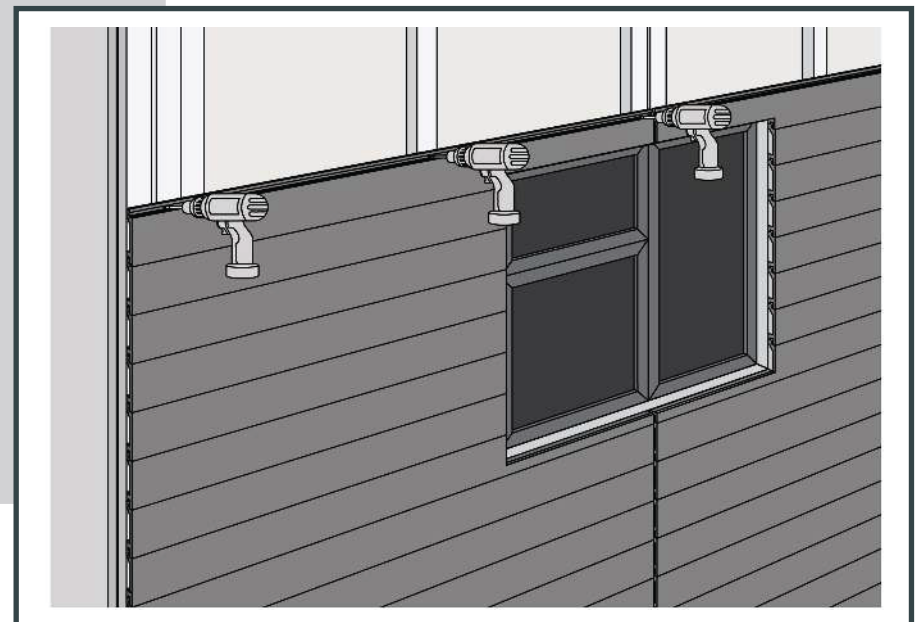
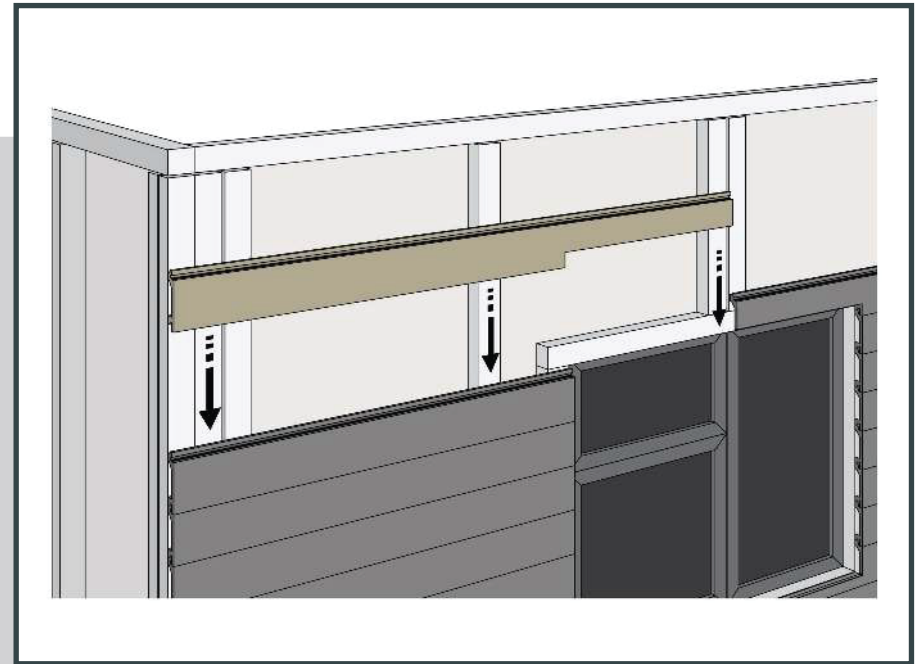

# INSTALLATION - VERTICAL CLADDING

## INSTALLING THE FINAL CLADDING BOARD

- 5 Install your final cladding board by fixing its concealed groove to the top groove of your penultimate board. If there is no need to cut your final cladding board, simply fix the top groove of the cladding board as you would any other.

If there is need to cut the final cladding board down its length, face fix the material using a screw fixing into the face of the product. See the guide on "Installation of Edging Options" (page 19) for finishing options.

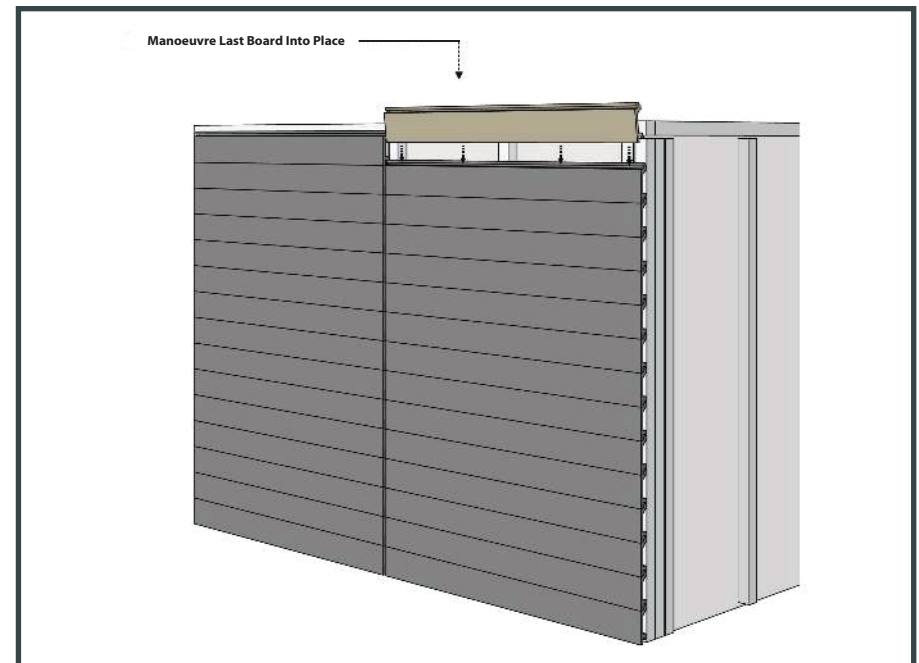
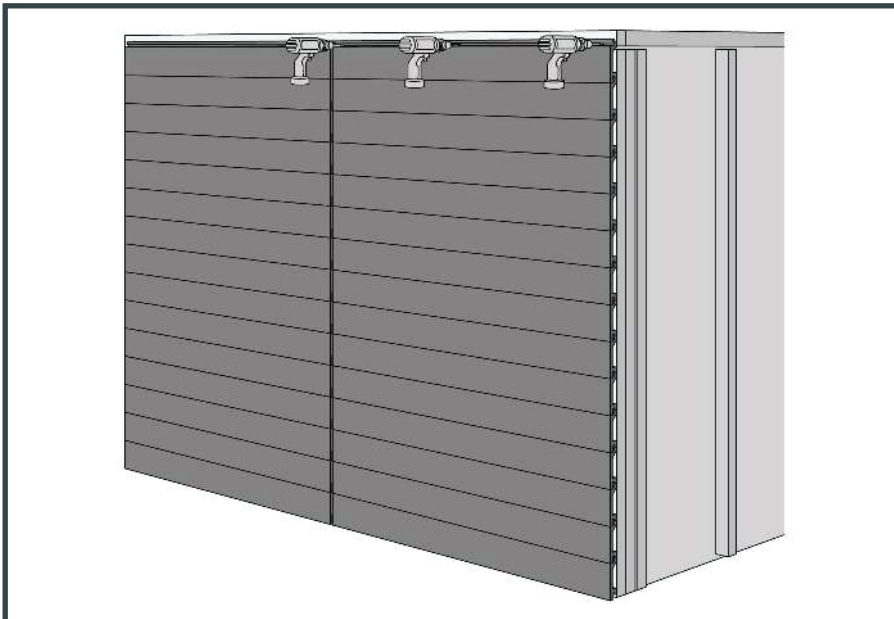

# INSTALLATION - VERTICAL CLADDING

## ALIGN & SECURELY FIX YOUR STARTER CLIPS TO THE FIRST RUN OF JOISTS

- 1 Starting at the edge of your project, begin attaching Starter Clips to the edge of your framework using the stainless screws provided. It is important that you mark a level line to ensure a straight and level line of Starter Clips are evenly fixed to your row of battens. Position and securely fix a Starter Clip at the furthest edge of each joist to ensure your first cladding board is securely fixed into place.

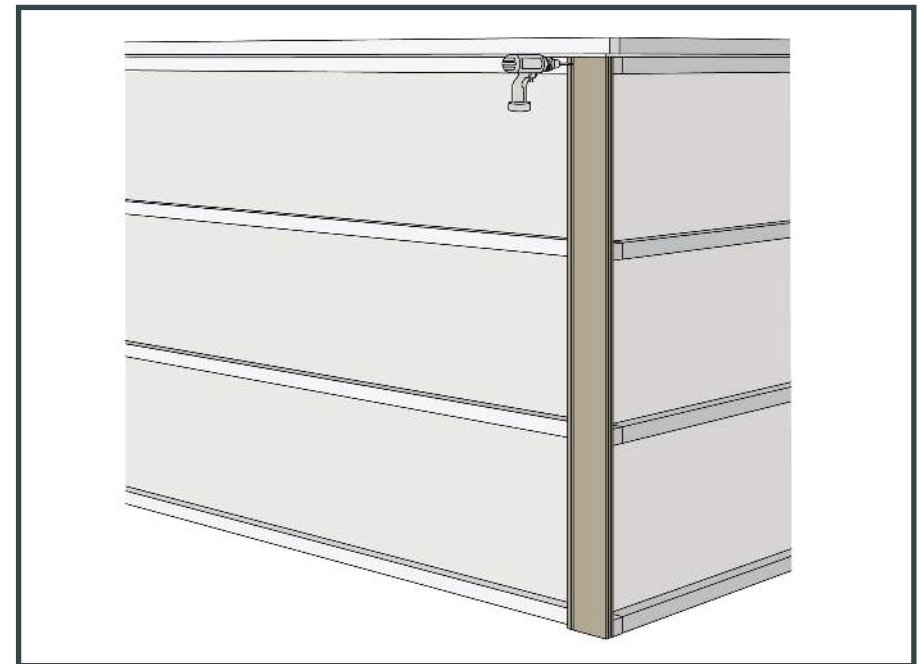

- 2 - 5 Follow the steps outlined in steps 2-5 of the "Horizontal Installation" guide (pages 14-17).



## INSTALLATION OF EDGING OPTIONS

A good edging solution can provide the finishing touches to your cladding installation and is used in most installations. Paveezzi provide 4 carefully designed Aluminium 2-part Trim solutions: Start & Finish trim, External Trim, Internal Trim, H trim Joiner. All designed to cap off exposed edges of a cladded area, cover expansion gaps and covering the returns on doors and windows. We outline the fixing methods involved with both our skirting and corner trim.

# INSTALLTION - CORNER & SKIRTING TRIM

## USING OUR EDGING TRIMS AROUND WINDOWS & DOORS

When cladding the internal sections of a window or door, Paveezzi's range of edging options can be used. We provide installation guidance on two separate ways you can install these options.

### SKIRTING TRIM INSTALLATION

Cut the trim down to size and fix on the internal section of the windowsill, ensuring the exposed edge of the cladding boards are suitably concealed. Pre-drill the material and fix securely at 300mm intervals using Paveezzi's Colour-Coded Trim Screws.

### CORNER TRIM INSTALLATION

Cut the trim down to size and ensure each length is mitred at a 45-degree angle where trims are expected to meet at corners. Fix onto the exposed corners of the window sill, ensuring the exposed edge of the cladding boards are suitably concealed. Pre-drill the material and fix securely at 300mm intervals using Paveezzi's Colour-Coded Trim Screws.

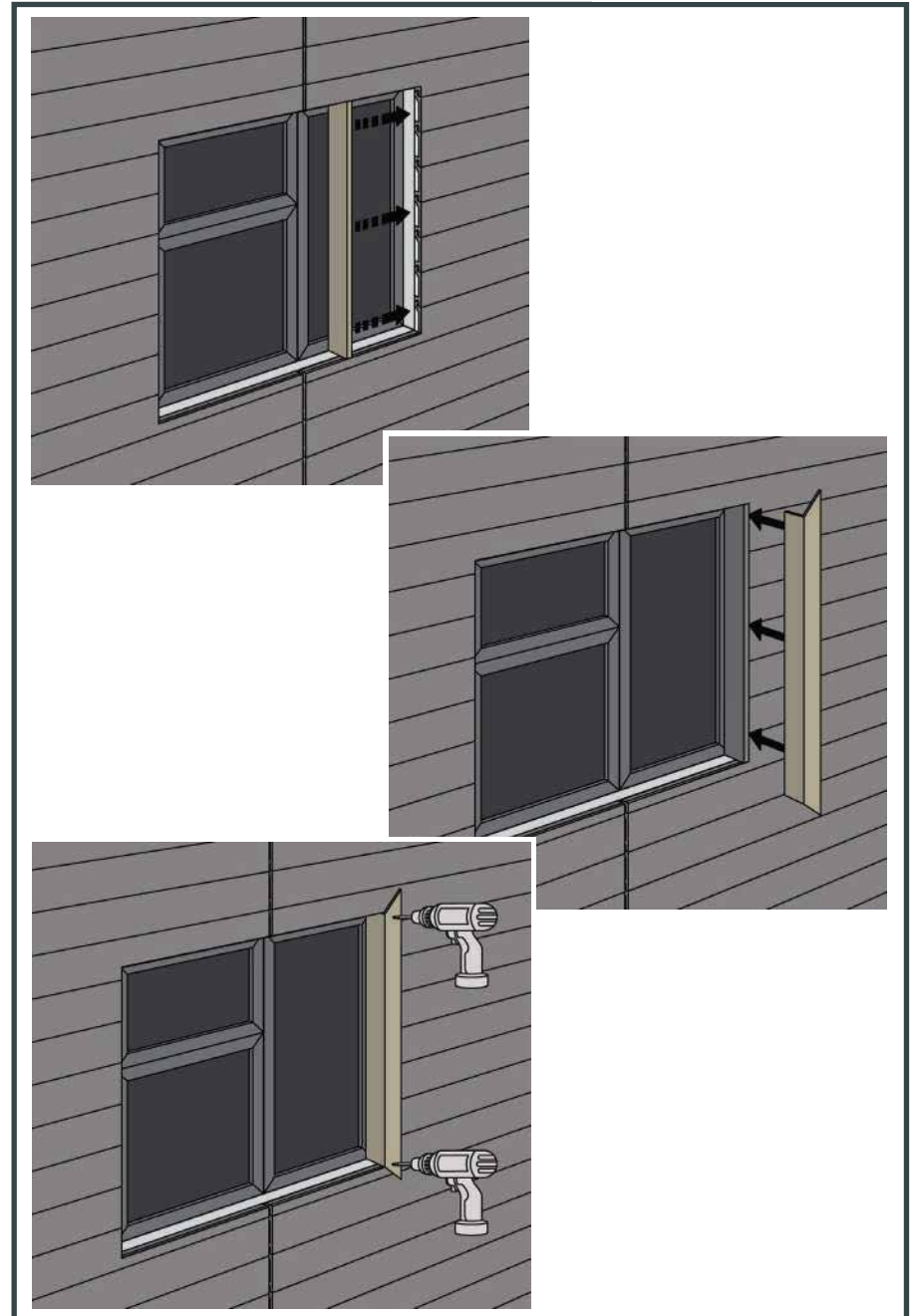

# INSTALLTION - WPC CORNER & SKIRTING TRIM

## INSTALLING OUR EDGING OPTIONS TO COVER EXPOSED EDGES & EXPANSION GAPS

When cladding the internal sections of a window or door, Paveezzi's range of edging options can be used. We provide installation guidance on two separate ways you can install these options.

### COVERING YOUR FINAL CLADDING BOARDS WITH A SKIRTING TRIM

Cut the trim down to size and fix on the internal section of the window sill, ensuring the exposed edge of the cladding boards are suitably concealed. Pre-drill the material and fix securely at 300mm intervals using Paveezzi's Colour-Coded Trim Screws.

### COVERING EXPOSED EDGES & CORNERS WITH A CORNER TRIM

When faced with an exposed corner section whereby to rows of adjoining cladding boards are left exposed, Paveezzi's Corner Trim can be fixed. Measure the area and cut the L-Shaped Corner Trim to size; pre-drill the material and then fix securely using Paveezzi's Coloured Trim Screw. Fix at every 300mm along its length.

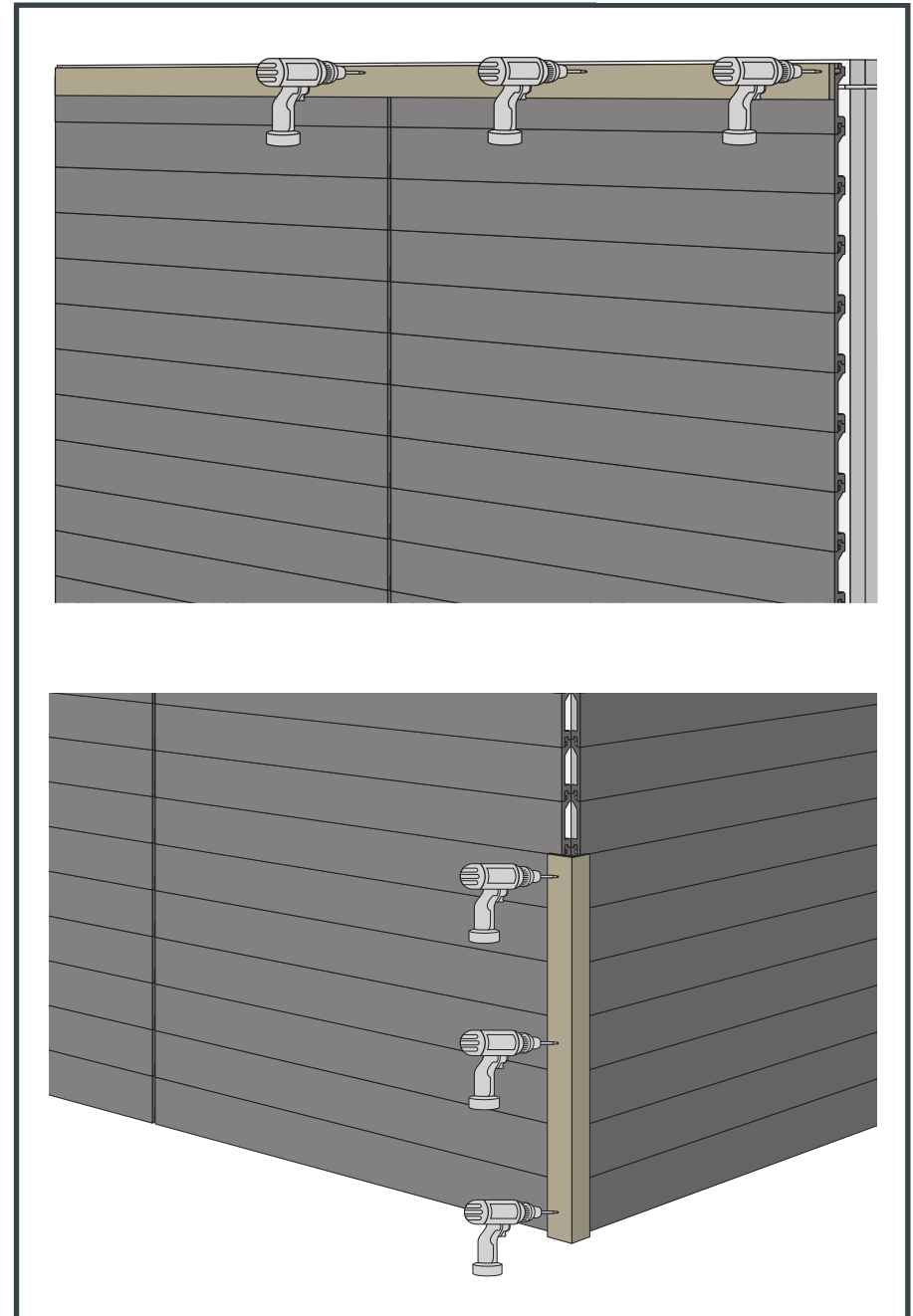



## CLEANING & CARE GUIDE

Our low-maintenance composite cladding comes with the reassurance of continual performance year-on-year, however we know that with a little care and attention once in a while, our boards can continue to look their sparkling best. This section will give you some handy tips on how to care for your cladding.



## ROUTINE CLEANING

Paveezzi recommend a routine clean of your cladding every 6 months to clear away dirt that can accumulate and sit on your boards over the course of time. We advise that proper safety precautions are taken when accessing the cladding.

**For a general clean** - We recommend applying warm soapy water to the surface of the cladding boards and cleaning with a soft bristled brush or sponge.

**For a deeper clean** - You can opt for using a jet wash with no greater than 3100 PSI to clear surface debris from your cladded area. Using the fan attachment, ensure that this is not applied any closer than 250mm away from the surface of the boards. Following these tips will ensure you preserve the long-term finish of the board.

Regardless of which cleaning option you choose, be sure to clean along the length of the boards to avoid accumulation of material that can interfere with drainage.

## STUBBORN SPOT STAINS

For stubborn stains, we recommend that you use similar techniques outlined in the Routine Cleaning section as well as following the advice below:

- Treat the affected area within the first 7-days
- A water-based composite cladding cleaner can be used which is designed specifically to remove excess oil from the surface of composite material.

Please note that the protective shell technology on our FineLine & Castellated ranges means that they are highly stain-resistant and must not be sanded under any circumstances.

## WATER STAINING

Although great care is taken in the manufacturing process of our products, there are a few methods that you can follow to speed this process up:

- Use warm soapy water to thoroughly clean the affected boards. Again, you may wish to use a jet wash on the affected area to assist with the removal of surface residue.
- To further speed-up this process, use a composite cladding brightener, which is specifically designed to remove the residual oils present in the boards.

Our FineLine & Castellated range cladding boards are protected with a polymer sleeve, which ensures the oils within its composite core do not leach-out onto the surface. This makes this type of board highly resistant to the effects of water staining.

## SURFACE MILDEW AND MOULD GROWTH





All outdoor surfaces can attract mould and mildew growth and while our cladding products are resistant to the damaging effects of this, it can still appear on the surface of the product and will require a level of cleaning and care. This tends to be most prominent after winter time and we recommend saving a deep clean of your Paveezzi cladding for the Spring time.

Mould and mildew growth can be removed by applying warm soapy water with a sponge and/or soft bristled brush. For particularly damp areas or areas that are situated near foliage or trees, the level of mould and mildew growth may be increased. If it is accessible and safe to do so, a jet wash can be used to clean the surface of the product in order to provide a deeper clean. A composite-specific cleaning product can be used as an effective de-greaser and cleaning agent.







For more helpful information on installing your cladding or any of our other products please visit [www.paveezzicomposites.com.au](http://www.paveezzicomposites.com.au)

## AUSTRALIA

-  [info@paveezzicomposites.com.au](mailto:info@paveezzicomposites.com.au)
-  1800 PAVEZI (728394)
-  [www.paveezzicomposites.com.au](http://www.paveezzicomposites.com.au)
-  164 Hoddle Street, Abbotsford 3067

## NEW ZEALAND

-  [sales@paveezzi.co.nz](mailto:sales@paveezzi.co.nz)
-  0800 728 339
-  [paveezzi.co.nz](http://paveezzi.co.nz)
-  622a Mt Albert Road Royal oak 1023, Auckland  
New Zealand